

DUAL AXIS SOLAR TRACKING WORM GEAR

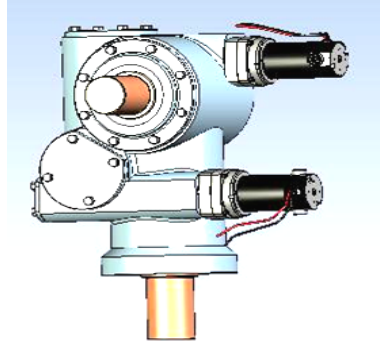

**Product
Under
Development**

Ratings are for preliminary selection - actual duty cycle and loads should be reviewed by Winsmith before final selection

Product Model	Worm Gear Center Distance	Ratio (2) (3)	Normal Operating Torque in lbs	Max Operating Torque in lbs	Max Static Torque in lbs	Max Overturning Moment in lbs	Static Axial Load Capacity lbs	Static Radial Load Capacity lbs	Standard Maximum Backlash arc min	Low Maximum Backlash arc min	Maximum Output Shaft Diameter in
DST20	2.00"	3200:1	1,504	3,081	5664	CF	CF	CF	12	3	2.00 (50.8)
DST24	2.38"	3200:1	2,348	4,808	9,338	CF	CF	CF	11	3	2.25 (57.3)
DST26	2.63"	3200:1	3,151	6,453	12,586	CF	CF	CF	11	3	2.50 (63.5)
DST30	3.00"	3200:1	4,533	9,283	18,655	CF	CF	CF	10	3	2.63 (66.7)
DST35	3.50"	3200:1	6,743	13,808	31,491	CF	CF	CF	10	3	2.87 (73)
DST43	4.25"	3200:1	10,310	21,113	55,482	CF	CF	CF	9	3	3.87 (98.4)
DST100 (1)	10.00"	18,000:1	115,000	350,000	1,000,000	1,730,000	CF	CF	3	3	(1)

CF Contact Factory
(1) Special version available

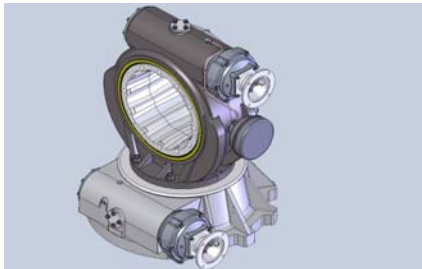

Azimuth bolt circle 26.50" (673.1)
Elevation bolt circle 14.50" (368.3)

- (2) Ratios up to 240,000:1 available with additional input reduction stages
- (3) Unit will not backdrive under most conditions

DISCLAIMER This information is intended to provide general guidance to assist in making the proper product selection for an application.

While this information is believed to be accurate, it is based on assumptions, calculations, information provided by others and, in some cases, not limited and specific laboratory tests, and on actual field conditions or applications. As such, it does not represent a guarantee with respect to characteristics or performance of the product in any given application or use. Winsmith products are intended for selection and use by trained and skilled persons capable of determining their suitability for the specific application or use. The purchaser or user is obligated to determine the suitability of products for the application or use. This information is subject to correction or change by Winsmith without notice. Please consult the Winsmith website for most recent updates



172 EATON STREET • SPRINGVILLE, NY 14141
Phone: (716) 592-9310 • Fax: (716) 592-9546 • www.WINSMITH.com