

MODEL†	910	913	917	920	924	926	930	935	943
DT SHIPPING WEIGHT	8	13	20	22	39	41	57	80	122
MDT SHIPPING WEIGHT‡	10	16	23	25	43	45	61	84	127
CDT SHIPPING WEIGHT‡	13	19	27	29	48	50	67	90	132
APPROX. OIL CAPACITY (PINTS)	.2	.2	.5	.5	1.0	1.2	1.7	2.3	3.1

MODEL DT
Assembly L

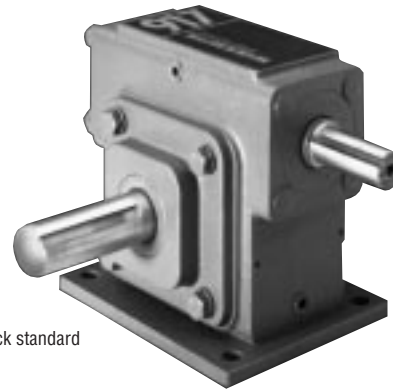

This model is stock standard in all sizes.

GEAR RATIOS AVAILABLE 4:1 THRU 100:1**
 TORQUE AND HP RATINGS/OVERHUNG LOAD RATINGS PAGES 20-117
 MOUNTING POSITIONS PAGE 187
 SERVICE FACTORS PAGES 228-230
 HYDRAULIC MOTOR ADAPTERS PAGE 174

†Weights are approximate and include shipping carton.
 ‡Weight given for 48C thru 145TC. For 182/4TC and 213/5TC add 4 lbs.
 **80:1 and 100:1 not available for Size 913.

DIMENSIONS

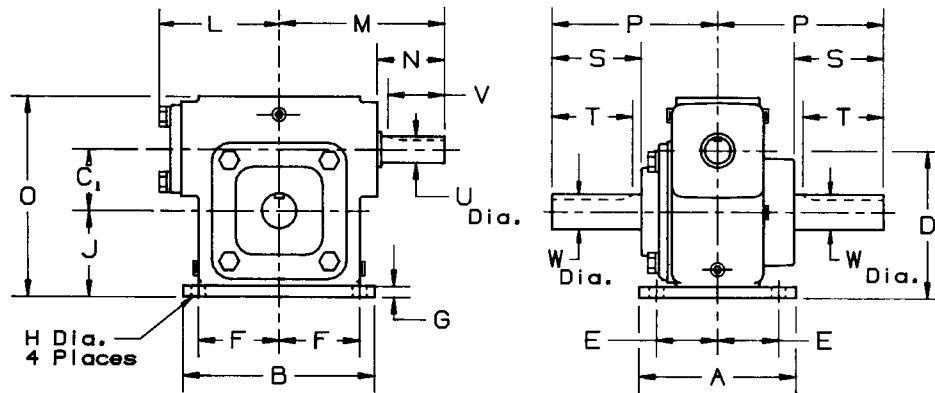

SPEED REDUCER DIMENSIONS (IN INCHES)

SIZE	A	B	C ₁	D	E	F	G	H	J	L	M	O	P	HIGH SPEED SHAFT				SLOW SPEED SHAFT				SIZE
														U*	N	V	KEYWAY	W*	S	T	KEYWAY	
910	3.69	4.62	1.000	2.75	1.44	1.88	.44	.344	1.75	1.70	2.88	4.07	2.88	.375	.75	.80	.09 x .05	.500	1.28	1.00	.13 x .06	910
913	4.00	5.00	1.333	3.33	1.63	2.13	.25	.281	2.00	2.83	4.12	4.58	4.00	.625	1.81	1.63	.19 x .09	.750	2.06	1.88	.19 x .09	913
917	4.50	5.50	1.750	4.19	1.75	2.31	.31	.406	2.44	3.44	4.75	5.69	4.75	.750	1.94	1.69	.19 x .09	1.000	2.56	2.31	.25 x .13	917
920	4.50	5.88	2.000	4.63	1.88	2.50	.50	.406	2.63	3.44	5.00	6.13	4.75	.750	2.19	1.75	.19 x .09	1.000	2.56	2.31	.25 x .13	920
924	4.50	7.00	2.375	5.63	1.88	3.13	.38	.406	3.25	4.50	6.50	7.63	5.50	1.000	2.75	2.38	.25 x .13	1.250	2.81	2.63	.25 x .13	924
926	4.50	7.50	2.625	6.13	1.88	3.25	.38	.406	3.50	4.50	6.50	8.25	5.50	1.000	2.75	2.38	.25 x .13	1.250	2.81	2.63	.25 x .13	926
930	6.00	8.00	3.000	7.00	2.38	3.50	.50	.563	4.00	4.63	7.00	9.50	5.88	1.000	3.06	2.38	.25 x .13	1.375	2.88	2.75	.31 x .16	930
935	6.50	10.00	3.500	8.00	2.63	4.13	.50	.563	4.50	5.06†	7.38	10.63	7.00	1.000	2.31	2.50	.25 x .13	1.750	3.75	3.63	.38 x .19	935
943	7.00	11.00	4.250	9.25	2.88	4.88	.63	.563	5.00	5.88‡	8.19	12.13	8.00	1.250	2.31	2.50	.25 x .13	2.000	4.38	4.19	.50 x .25	943

*Slow speed shaft diameter +.000 -.001. For construction purposes send for Certified Dimension Sheets.
 **4:1, 7.5:1, 60:1, 80:1, and 100:1 not available for Size 910.

For larger sizes see C-Line Catalog 100 or D-90[®] TYPE DE[®] Catalog 190.
 †L dimension equals 5.46 on MDT models.
 ‡L dimension equals 6.28 on MDT models.

SHAFT ARRANGEMENTS AND RELATIVE SHAFT ROTATIONS

AutoCAD[®] drawing for these models available in WINSMITH[®]'s Gear Graphics.

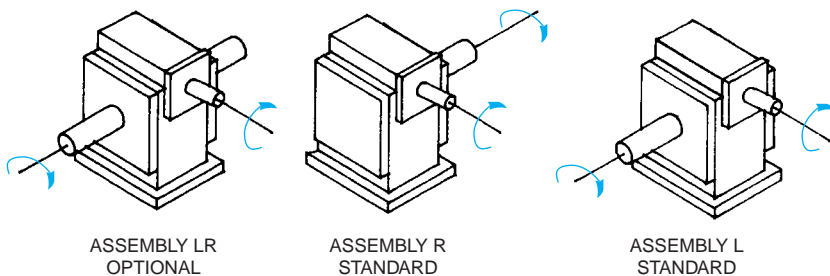

The input shaft may be driven in either direction.

MODEL MDT
Assembly L



MODEL CDT
Assembly L



This model is stock standard in all sizes.

Couplings available, see page 184 for Selection Chart.

DIMENSIONS

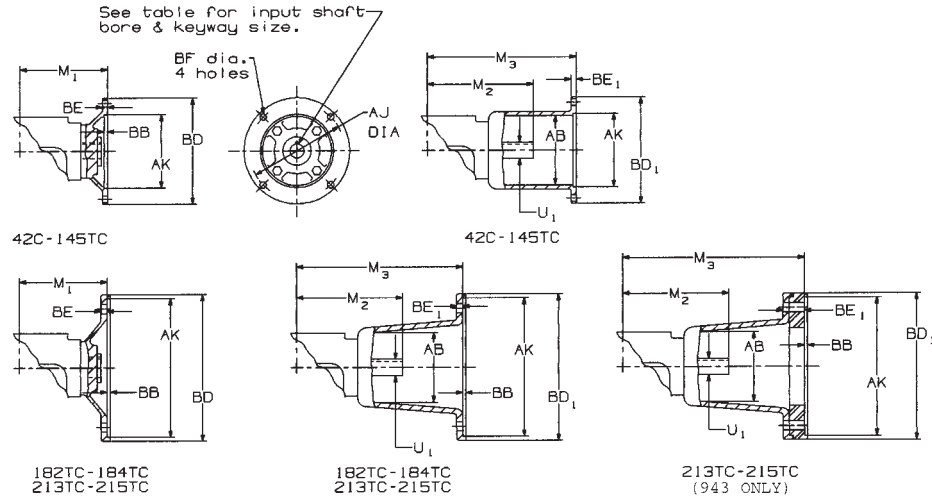

SIZE	HOLLOW INPUT MOTOR ADAPTER				COUPLING STYLE MOTOR ADAPTER											KEYWAY			
	M ₁ 42C-48C	M ₁ 56C-145TC	M ₁ 182TC-184TC	M ₁ 213TC-215TC	42C-48C			56C-145TC			182TC-184TC			213TC-215TC			M ₂ *	U ₁ *	
					AB	M ₃	BE ₁	AB	M ₃	BE ₁	AB	M ₃	BE ₁	AB	M ₃				BE ₁
910	3.57	3.74 Δ	NA	NA	2.63	4.44	.42	2.63	5.23	.42	NA			NA			2.88	.374	.09 x .05
913	3.56	3.63 Δ	NA	NA	2.50	6.81	.38	3.00	6.75	.31	NA			NA			4.12	.500	.13 x .06
917	4.06	4.06	NA	NA	2.50	7.56	.38	3.75	7.50	.38	3.75	8.44	.50	NA			4.88	.625	.19 x .09
920	4.06	4.06	NA	NA	2.50	7.56	.38	3.75	7.50	.38	3.75	8.44	.50	NA			4.88	.625	.19 x .09
924	NA	5.38	5.38	NA	NA			4.13	9.13	.38	4.25	10.19	.50	NA			6.50	1.000	.25 x .13
926	NA	5.38	5.38	NA	NA			4.13	9.13	.38	4.25	10.19	.50	NA			6.50	1.000	.25 x .13
930	NA	5.56	5.56	NA	NA			4.13	9.75	.38	4.75	10.88	.50	4.75	10.88	.50	7.00	1.000	.25 x .13
935	NA	5.81	5.81	NA	NA			4.13	10.00	.38	4.75	11.13	.50	4.75	11.13	.50	7.38	1.000	.25 x .13
943	NA	6.63	6.63	6.63	NA			4.13	10.81	.38	4.75	11.94	.50	4.75	12.88	1.44	8.19	1.250	.25 x .13

*Input shaft diameter and length varies from non-motorized model on sizes 913 thru 920.
 Δ 56C frame only.

SHAFT ARRANGEMENTS AND RELATIVE SHAFT ROTATIONS

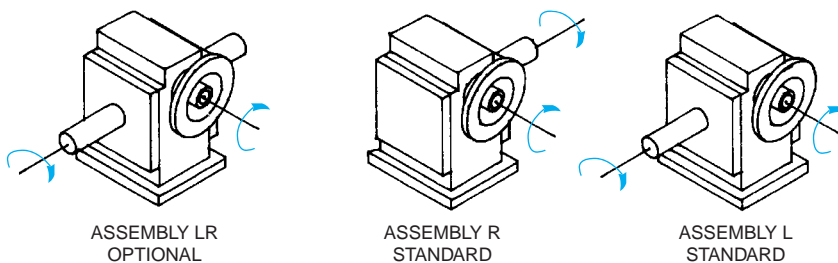

FRAME NO.	42C-48C	56C	143TC-145TC	182TC-184TC	213TC-215TC
AJ	3.75	5.88	5.88	7.25	7.25
AK	3.00	4.50	4.50	8.50	8.50
BB	.19	.19	.19	.19	.19
BD	4.50	6.50	6.50	9.00	9.00
BD ₁	4.50*	6.63	6.63	9.00	9.00
BE	.34	.31	.31	.38	.38
BF	.281	.406	.406	.531	.531
KEYWAY	.13 x .06		.19 x .09		.25 x .13
BORE	$^{+.001}_{-.000}$.6255	.8755	1.1255	1.3755

□ 42C frame has .3755 bore, .094 x .047 keyway.
 *BD₁=4.63 on size 910.

The input shaft may be driven in either direction.