

MODEL†	917	920	924	926	930	935	943
DSN SHIPPING WEIGHT	15	19	36	38	50	78	126
MDSN SHIPPING WEIGHT‡	18	22	40	42	54	82	131
CDSN SHIPPING WEIGHT‡	22	26	45	47	60	88	136
APPROX. OIL CAPACITY (PINTS)	.5	.5	.9	1.2	1.6	2.1	2.8

MODEL DSN  
Assembly DR

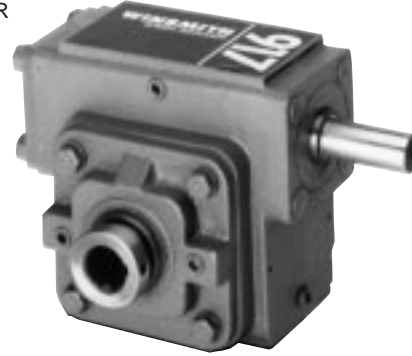

GEAR RATIOS AVAILABLE 4:1 THRU 100:1  
 TORQUE AND HP RATINGS/OVERHUNG LOAD RATINGS . . . . . PAGES 20-117  
 MOUNTING POSITIONS . . . . . PAGE 187  
 SERVICE FACTORS . . . . . PAGES 228-230  
 HYDRAULIC MOTOR ADAPTERS . . . . . PAGE 174  
 BASE AND BRACKET KITS . . . . . PAGES 183-186

†Weights are approximate and include shipping carton.  
 ‡Weight given for 48C thru 145TC. For 182/4TC and 213/5TC add 4 lbs.

## DIMENSIONS

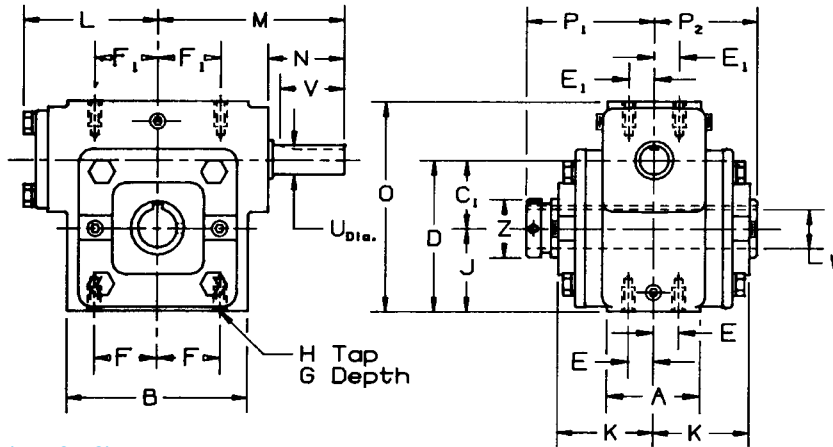

## SPEED REDUCER DIMENSIONS (IN INCHES)

SIZE	A	B	C <sub>1</sub>	D	E	E <sub>1</sub>	F	F <sub>1</sub>	G DEPTH	H TAP	J	K	L	M	O	P <sub>1</sub>	P <sub>2</sub>	Z	HIGH SPEED SHAFT				SIZE
																			U*	N	V	KEYWAY	
917	2.38	4.63	1.750	3.88	.88	.88	1.94	1.69	.56	3/8-16	2.13	2.44	3.44	4.75	5.38	3.25	2.63	1.49	.750	1.94	1.69	.19 x .09	917
920	2.38	5.25	2.000	4.13	.88	.88	2.19	1.69	.56	3/8-16	2.13	2.63	3.44	5.00	5.63	3.38	2.88	2.00	.750	2.19	1.75	.19 x .09	920
924	3.13	5.38	2.375	5.25	1.13	1.13	2.19	2.19	.63	1/2-13	2.88	2.75	4.50	6.50	7.25	3.56	2.94	2.25	1.000	2.75	2.38	.25 x .13	924
926	3.13	5.88	2.625	5.75	1.13	1.13	2.44	2.44	.63	1/2-13	3.13	2.81	4.50	6.50	7.88	3.69	3.00	2.50	1.000	2.75	2.38	.25 x .13	926
930	3.50	6.62	3.000	6.50	1.31	1.31	2.75	2.75	.75	1/2-13	3.50	3.00	4.63	7.00	9.00	4.06	3.19	2.63	1.000	3.06	2.38	.25 x .13	930
935	3.75	7.69	3.500	7.50	1.31	1.31	3.25	3.25	1.00	5/8-11	4.00	3.38	5.06†	7.38	10.13	4.44	3.56	2.87	1.000	2.31	2.50	.25 x .13	935
943	4.38	8.75	4.250	8.63	1.63	1.63	3.75	3.75	1.00	5/8-11	4.38	3.63	5.88‡	8.19	11.50	4.38	4.38	3.88	1.250	2.31	2.50	.25 x .13	943

\*Shaft diameter tolerance +.000 -.001. For construction purposes send for Certified Dimension Sheets.  
 †L dimension equals 5.46 on MDSN models.

For larger sizes see C-Line Catalog 100 or D-90<sup>®</sup> TYPE DE<sup>®</sup> Catalog 190.  
 ‡L dimension equals 6.28 on MDSN models.

## SLOW SPEED SHAFT BORES<sup>1, 2, 3, 4</sup>

917		920		924		926		930		935		943	
W**	KEYWAY	W**	KEYWAY	W**	KEYWAY	W**	KEYWAY	W**	KEYWAY	W**	KEYWAY	W**	KEYWAY
.625	.19 x .09	<b>.750</b>	<b>.19 x .09</b>	.875	.19 x .09	.938	.25 x .13	1.188	.25 x .13	1.188	.25 x .13	1.625	.38 x .19
.688	.19 x .09	.813	.19 x .09	.938	.25 x .13	1.000	.25 x .13	1.250	.25 x .13	1.250	.25 x .13	1.688	.38 x .19
<b>.750</b>	<b>.19 x .09</b>	<b>.875</b>	<b>.19 x .09</b>	1.000	.25 x .13	1.063	.25 x .13	<b>1.375</b>	<b>.31 x .16</b>	<b>1.375</b>	<b>.31 x .16</b>	1.750	.38 x .19
.813	.19 x .09	.938	.25 x .13	1.063	.25 x .13	1.125	.25 x .13	<b>1.438</b>	<b>.38 x .19</b>	1.438	.38 x .19	1.875	.50 x .25
.875	.19 x .09	<b>1.000</b>	<b>.25 x .13</b>	<b>1.125</b>	<b>.25 x .13</b>	1.188	.25 x .13	<b>1.500</b>	<b>.38 x .19</b>	<b>1.500</b>	<b>.38 x .19</b>	1.938	.50 x .25
.938	.25 x .13	1.063	.25 x .13	1.188	.25 x .13	<b>1.250</b>	<b>.25 x .13</b>	<b>1.625</b>	<b>.38 x .19</b>	1.625	.38 x .19	2.000	.50 x .25
<b>1.000</b>	<b>.25 x .13</b>	<b>1.125</b>	<b>.25 x .13</b>	<b>1.250</b>	<b>.25 x .13</b>	1.375	.31 x .16	1.688	.38 x .19	1.688	.38 x .19	2.188	.50 x .25
		1.188	.25 x .13	1.375	.31 x .16	<b>1.438</b>	<b>.38 x .19</b>	<b>1.750</b>	<b>.38 x .19</b>	1.750	.38 x .19	2.250	.50 x .25
		<b>1.250</b>	<b>.25 x .13</b>	<b>1.438</b>	<b>.38 x .19</b>	<b>1.500</b>	<b>.38 x .19</b>	<b>1.875</b>	<b>.50 x .25</b>	<b>1.875</b>	<b>.50 x .25</b>	2.438	.63 x .31
		1.375	.31 x .16	<b>1.500</b>	<b>.38 x .19</b>	1.625	.38 x .19	<b>1.938</b>	<b>.50 x .19</b>	<b>1.938</b>	<b>.50 x .25</b>	2.500	.63 x .31
		<b>1.438</b>	<b>.38 x .13</b>			<b>1.688</b>	<b>.38 x .19</b>			<b>2.000</b>	<b>.50 x .25</b>	2.688	.63 x .31
										<b>2.188</b>	<b>.50 x .13</b>	2.750	.63 x .31

\*\*Bore tolerances +.000, +.002.

2. Hollow output shaft bored to size; no bushing kit required.

4. Bores in bold blue type are stock standard sizes.

1. Contact factory for other bore sizes.

3. Puller groove on all hollow output shafts.



**D-90<sup>®</sup> TYPE SE<sup>®</sup>**

# MDSN-CDSN

**MODEL MDSN**  
Assembly DR



**MODEL CDSN**  
Assembly DR



Couplings available, see page 184 for Selection Chart.

## DIMENSIONS

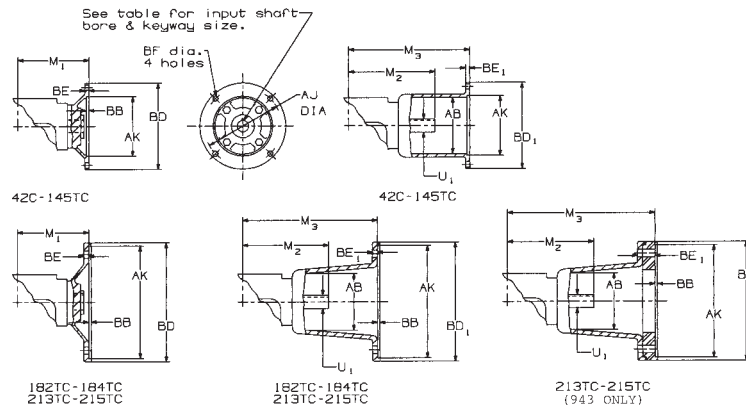

SIZE	HOLLOW INPUT MOTOR ADAPTER				COUPLING STYLE MOTOR ADAPTER														
	M <sub>1</sub> 42C-48C	M <sub>1</sub> 56C-145TC	M <sub>1</sub> 182TC 184TC	M <sub>1</sub> 213TC 215TC	42C-48C			56C-145TC			182TC-184TC			213TC-215TC			M <sub>2</sub> *	U <sub>1</sub> *	KEYWAY
					AB	M <sub>3</sub>	BE <sub>1</sub>	AB	M <sub>3</sub>	BE <sub>1</sub>	AB	M <sub>3</sub>	BE <sub>1</sub>	AB	M <sub>3</sub>	BE <sub>1</sub>			
917	4.06	4.06	NA	NA	2.50	7.56	.38	3.75	7.50	.38	3.75	8.44	.50	NA			4.88	.625	.19 x .09
920	4.06	4.06	NA	NA	2.50	7.56	.38	3.75	7.50	.38	3.75	8.44	.50	NA			4.88	.625	.19 x .09
924	NA	5.38	5.38	NA	NA			4.13	9.13	.38	4.25	10.19	.50	NA			6.50	1.000	.25 x .13
926	NA	5.38	5.38	NA	NA			4.13	9.13	.38	4.25	10.19	.50	NA			6.50	1.000	.25 x .13
930	NA	5.56	5.56	NA	NA			4.13	9.75	.38	4.75	10.88	.50	4.75	10.88	.50	7.00	1.000	.25 x .13
935	NA	5.81	5.81	NA	NA			4.13	10.00	.38	4.75	11.13	.50	4.75	11.13	.50	7.38	1.000	.25 x .13
943	NA	6.63	6.63	6.63	NA			4.13	10.81	.38	4.75	11.94	.50	4.75	12.88	1.44	8.19	1.250	.25 x .13

\*Input shaft diameter and length varies from non-motorized model on sizes 913 thru 920.  
 □ 42C frame has .3755 bore, .094 x .047 keyway.

FRAME NO.	42C-48C	56C	143TC 145TC	182TC 184TC	213TC 215TC
AJ	3.75	5.88	5.88	7.25	7.25
AK	3.00	4.50	4.50	8.50	8.50
BB	.19	.19	.19	.19	.19
BD	4.50	6.50	6.50	9.00	9.00
BD <sub>1</sub>	4.50	6.63	6.63	9.00	9.00
BE	.34	.31	.31	.38	.38
BF	.281	.406	.406	.531	.531
KEYWAY	.13 x .06	.19 x .09		.25 x .13	.31 x .16
BORE	<sup>+.001</sup> <sub>-.000</sub>	.5005□	.6255	.8755	1.1255

AutoCAD<sup>®</sup> drawing for these models available in WINSMITH<sup>®</sup>'s Gear Graphics.

## SHAFT ARRANGEMENTS AND RELATIVE SHAFT ROTATIONS

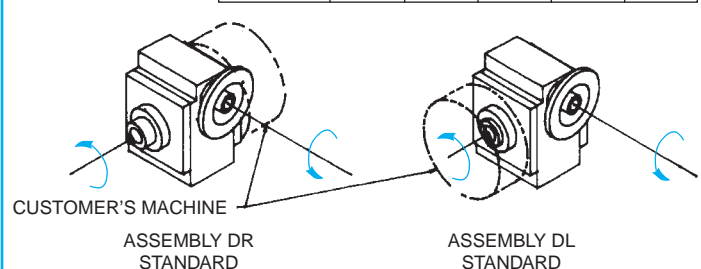
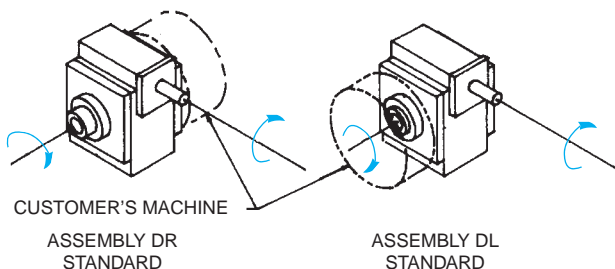

The input shaft may be driven in either direction.