

STANDARD SINGLE EXTENDED DOUBLE ENVELOPING WORMS

D-90[®] TYPE DE[®]



Dashed line indicates fan extension.

Double extended available upon request.

Worms and gears sold as matched set only.

The mechanical rating can be found in the unit rating section of this catalog.

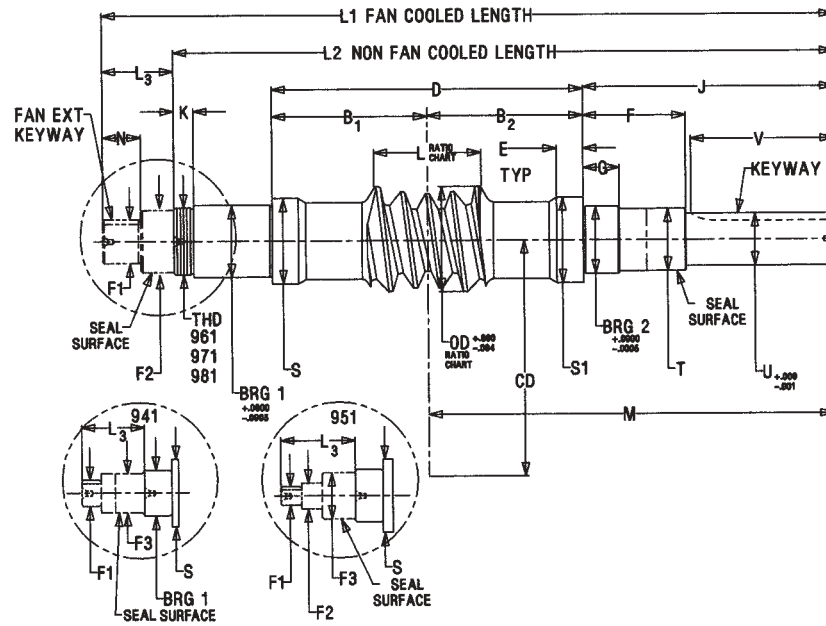

SIZE	B ₁	B ₂	BRG1	BRG2	CD	D	E	F	F1	F2	F3	G
941	3.2352	NA	1.7515	1.7515	3.937	6.465	.25	2.179	1.000	NA	1.500	1.05
951	4.2007	NA	2.0007	2.0007	4.921	8.403	.38	2.321	.7091	.986	1.772	1.05
961	4.634	NA	2.2507	1.9697	5.906	9.902	.50	2.604	1.102	1.772	NA	1.48
971	NA	5.318	2.3634	2.3634	6.890	10.303	.75	3.539	1.299	2.165	NA	1.18
981	NA	5.925	2.7507	2.5603	7.874	11.850	1.00	3.914	1.674	2.362	NA	1.38

SIZE	J	K	L1	L2	L3	M	N	S	S1	T	U	V	KEYWAY	FAN EXT KEYWAY
941	5.768	NA	15.69	13.28	2.41	9.00	.75	2.561	2.561	NA	1.500	3.25	3/8 x 3/16	1/4 x 1/8
951	5.524	NA	17.82	14.98	2.84	9.73	.79	2.800	2.800	1.772	1.500	3.06	3/8 x 3/16	5MM x 3MM
961	5.834	.64	21.22	18.85	2.37	11.10	.98	2.652	2.502	1.969	1.750	3.12	3/8 x 3/16	7MM x 4MM
971	7.932	.75	24.98	21.94	3.04	13.25	1.15	3.250	3.250	2.165	1.750	4.25	3/8 x 3/16	7MM x 4MM
981	9.575	.75	27.90	25.17	2.73	15.50	1.38	3.250	3.250	2.362	2.000	5.47	1/2 x 1/4	10MM x 4MM

RATIO CHART

RATIO	SIZE 941		SIZE 951		SIZE 961		SIZE 971		SIZE 981	
	OD	L	OD	L	OD	L	OD	L	OD	L
5	2.877	1.322	3.870	1.992	4.422	2.010	5.257	3.076	5.992	2.882
8	2.326	1.420	3.700	2.266	4.286	2.680	4.494	3.162	5.371	4.014
10	2.254	1.532	3.319	2.294	4.022	2.686	4.640	3.340	5.137	4.014
15	2.673	1.888	3.571	2.392	3.839	2.852	3.808	3.358	4.743	4.032
20	2.518	1.814	3.366	2.430	3.679	2.880	3.935	3.340	4.879	4.012
25	2.021	1.834	2.734	2.438	3.561	2.902	3.462	3.372	3.918	4.048
30	2.090	2.192	2.658	2.658	3.386	3.120	3.311	3.394	3.778	4.074
40	2.233	2.140	2.846	2.422	3.207	3.252	3.787	3.524	4.162	4.012
50	2.155	2.058	2.776	2.598	3.056	3.178	3.558	3.564	3.887	4.046
60	2.065	2.034	2.657	2.516	2.906	3.102	3.460	3.682	3.807	4.172
70	1.986	2.048	2.569	2.490	2.834	3.116	3.373	3.700	3.377	4.192
80	1.918	1.956	2.495	2.440	2.769	3.126	3.286	3.614	3.363	4.204
100	1.850	1.966	2.454	2.552	2.647	3.044	3.185	3.630	3.203	4.232

Check with factory for other dimensions.
Dimensions could be changed by WINSMITH without notice.



SOLID SHAFT GEAR

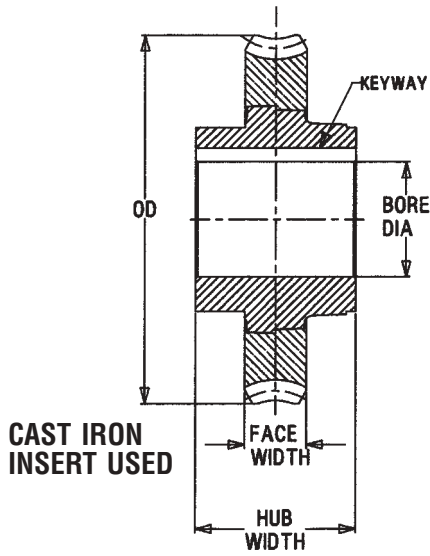

HOLLOW SHAFT GEAR

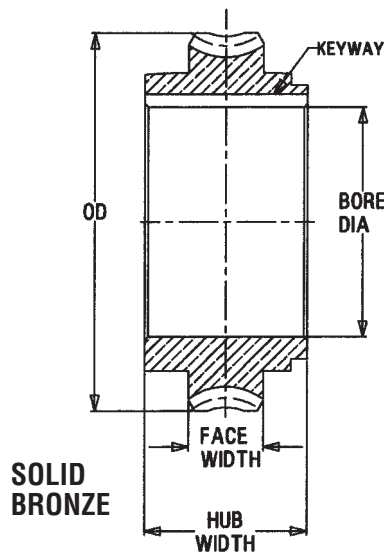

OPTIONAL FLANGE GEAR

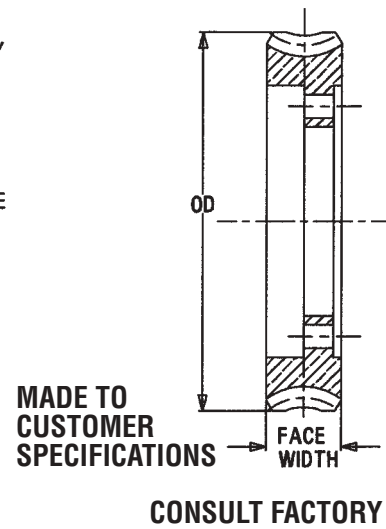

DIMENSION CHART SOLID SHAFT GEAR

SIZE	CD	BORE DIA	KEYWAY	HUB WIDTH	FACE WIDTH
941	3.937	2.2492 / 2.2506	1/2 x 1/4	2.502 / 2.498	1.230
951	4.921	2.6242 / 2.6256	3/4 x 3/8	3.152 / 3.148	1.450
961	5.906	3.1871 / 3.1844	3/4 x 3/8	4.333 / 4.329	1.731
971	6.890	3.6606 / 3.6622	1 x 1/2	5.120 / 5.119	2.060
981	7.874	3.9996 / 4.0009	1 x 1/2	6.302 / 6.298	2.305

HOLLOW SHAFT AND FLANGE GEAR

SIZE	CD	BORE DIA	KEYWAY	HUB WIDTH	FACE WIDTH
941	3.937	4.2496 / 4.2509	1/2 x 1/4	3.002 / 2.998	1.230
951	4.921	4.9990 / 5.0006	5/8 x 5/16	4.127 / 4.123	1.450
961	5.906	5.7490 / 5.7506	3/4 x 3/8	3.627 / 3.623	1.731
971	6.890	6.9990 / 7.0006	1 x 1/2	5.002 / 4.998	2.060
981	7.874	6.9990 / 7.0000	1 x 1/2	5.574 / 5.570	2.305

GEAR OD (ALL 3 STYLES)

SIZE	RATIO												
	5	8	10	15	20	25	30	40	50	60	70	80	100
941	5.684	6.404	6.404	6.189	6.189	6.609	6.609	6.609	6.609	6.609	6.609	6.609	6.609
951	6.944	7.324	7.544	7.544	7.544	8.204	8.204	8.204	8.204	8.204	8.204	8.204	8.204
961	8.364	8.744	9.004	9.404	9.404	9.404	10.044	10.044	10.044	10.044	10.044	10.044	10.044
971	9.804	10.664	10.664	11.504	11.504	11.764	11.764	11.764	11.764	11.764	11.764	11.764	11.764
981	11.104	12.184	12.404	12.684	12.684	13.504	13.504	13.504	13.504	13.504	13.724	13.724	13.724

Check with factory for other dimensions.
Dimensions could be changed by WINSMITH without notice.

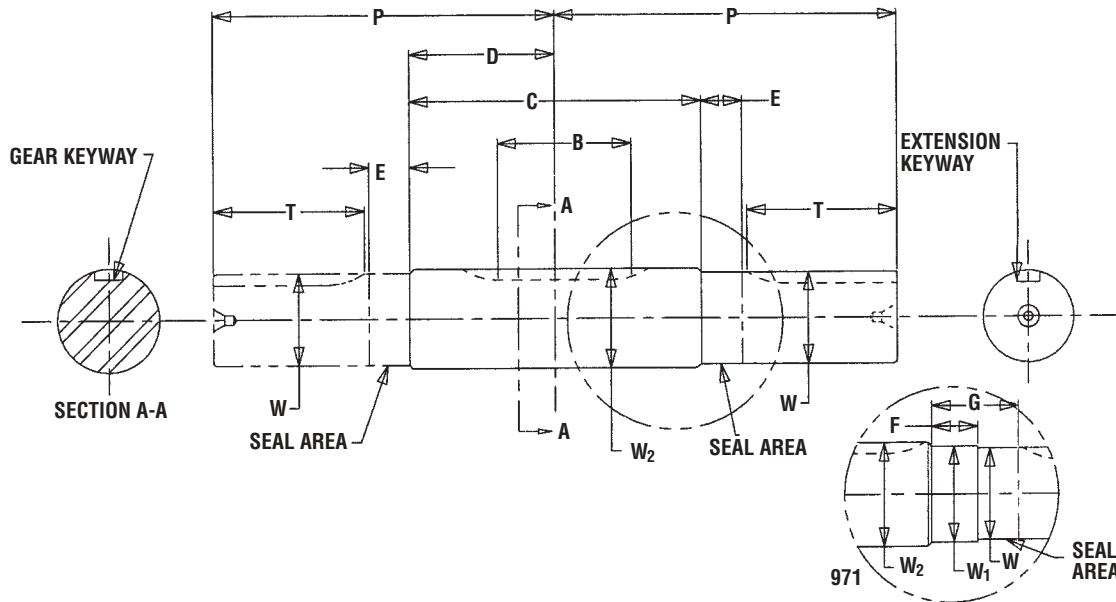

SOLID SLOW SPEED SHAFTS

SIZE	CENTER DISTANCE	EXTENSION KEYWAY	GEAR KEYWAY	B FULL DEPTH	C	D	E	F	G	P	T	W -.001	W ₁	W ₂ -.0005
941	3.937	1/2 x 1/4	1/2 x 1/4	2.50	8.00	4.00	1.00	NA	NA	9.25	4.19	2.250	NA	2.2515
951	4.921	5/8 x 5/16	3/4 x 3/8	3.15	8.00	4.00	1.13	NA	NA	9.38	4.13	2.500	NA	2.6265
961	5.906	3/4 x 3/8	3/4 x 3/8	4.33	9.55	4.80	1.38	NA	NA	11.50	5.25	3.125	NA	3.190*
971 [△]	6.890	7/8 x 7/16	1 x 1/2	5.13	7.62	3.81	1.38	1.63	3.01	13.50	6.56	3.500	3.545	3.6635*
981	7.874	1 x 1/2	1 x 1/2	6.19	12.56	6.31	1.44	NA	NA	15.50	7.69	3.875	NA	4.0025

Material—Steel

[△]See alternate view.

*Use these shafts with solid shaft gears.

*Check with factory for other dimensions.

*Dimensions could be changed by WINSMITH without notice.

*Tolerance W₂ size 961 is 3.190/3.189.

*Tolerance W₂ size 971 is 3.6635/3.6628.

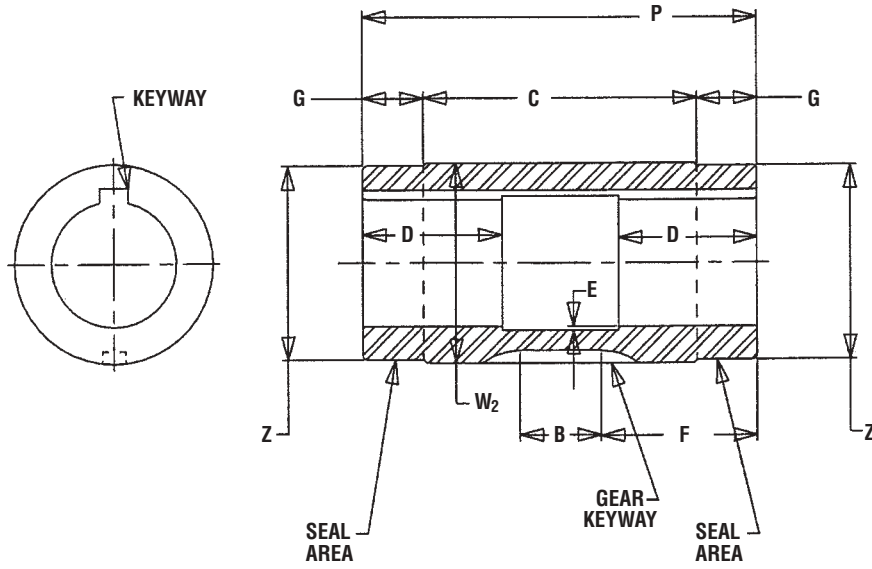

HOLLOW SLOW SPEED SHAFTS

SIZE	CENTER DISTANCE	GEAR KEYWAY	B FULL DEPTH	C	D	E	F	G	P	W ₂ -.001	Z -.002
941	3.937	1/2 x 1/4	1.750	5.88	3.00	.03	3.38	1.31	8.50	4.2525	4.125
951	4.921	5/8 x 5/16	4.125	7.13	3.25	.03	3.00	1.50	10.13	5.0025	4.875
961	5.906	3/4 x 3/8	3.62	7.08	3.25	.03	3.50	1.77	10.62	5.7525	5.748
971	6.890	1 x 1/2	5.000	10.38	4.50	.03	4.19	1.50	13.38	7.0025	6.750
981	7.874	1 x 1/2	5.572	9.38	4.50	.03	3.51	1.61	12.60	7.0025	6.750

SIZE	BORE*	KEYWAY
941	2.9375	5/8 x 5/16
951	3.4375	7/8 x 7/16
961	3.9375	1 x 3/8
971	4.4375	1 x 1/2
981	4.4375	1 x 1/2

Material—Steel

*Maximum available bore dia. Check with factory for smaller bore sizes. Bore tolerance +.000 +.002.

*Use these shafts with hollow shaft gears.

*Check with factory for other dimensions.

*Dimensions could be changed by WINSMITH without notice.