

Torque Arm Mounting Kits

Torque Arm (R)
 Quill Input Adaptor
 Hollow Output Shaft
 Bracket Mount

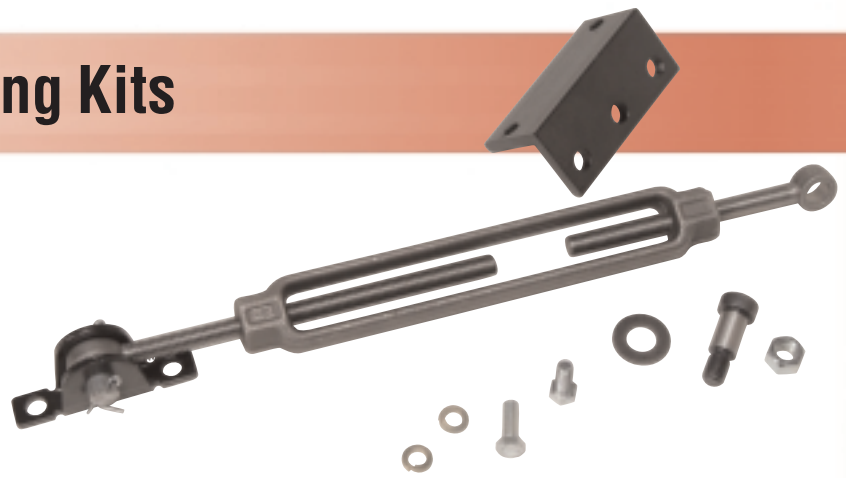

MDSS Shown With Mounted (R) Bracket Kit
 Hollow Output Shaft

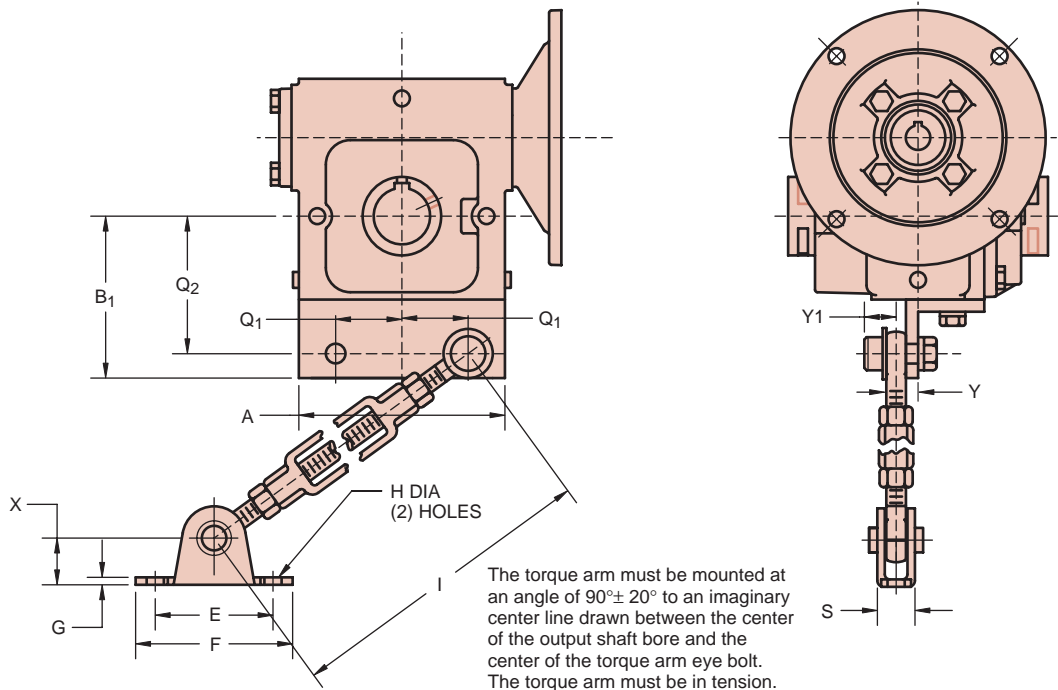

◆ Bracket Supplied Separately

SPEED REDUCER DIMENSIONS (in.)

Size	A	B ₁	E	F	G	H	I MIN	I MAX	Q ₁	Q ₂	S	Y	Y ₁	X	Kit#	Kit lb. ^a
E17	4.63	4.13	3.00	4.00	.19	.44	15.00	24.00	1.69	3.50	.75	.63	.81	1.19	TQ9952574	7
E20	5.25	4.13	3.00	4.00	.19	.44	15.00	24.00	1.69	3.50	.75	.63	.81	1.19	TQ9952442	7
E24	5.38	4.88	3.00	4.00	.19	.44	15.00	24.00	2.13	4.25	.75	.31	.81	1.19	TQ9952443	7
E26	5.88	5.13	3.00	4.00	.19	.44	15.00	24.00	2.31	4.50	.75	.44	.81	1.19	TQ9952444	7
E30	6.50	5.50	3.00	4.00	.19	.44	15.00	24.00	2.56	4.88	.75	.44	.81	1.19	TQ9952445	7
E35	7.75	6.50	3.50	4.75	.56	.53	21.00	29.00	3.00	5.63	2.13	.88	1.09	1.63	TQ9952446	13
E43	8.75	6.88	3.50	4.75	.56	.53	21.00	29.00	3.50	6.00	2.13	.56	1.09	1.63	TQ9952575	13

^a Approximate shipping weights

Multimount



2D DRAWINGS & 3D MODELS
 www.WINSMITH.com

