

Speed Reducer Self-Locking and Back-Driving

What is Self-Locking and Back-Driving?

The term self-locking, when applied to the operational performance characteristics of worm gear speed reducers, is defined as follows:

When an external load applies a dynamic or static torque to the output worm gear shaft, and this torque does not result in any rotation of the input worm, the reducer is considered self-locking.

Conversely, back-driving is the opposite effect and is defined as follows:

Back-driving occurs when an external load applies a dynamic or static torque to the output shaft and this torque does result in rotation of the input worm.

Depending on several design and load characteristics, worm gear speed reducers may be selected which either self-lock or back-drive and in some limited cases can do both depending on external loads and operational conditions. In most normal applications of a worm gear speed reducer, the input worm shaft is powered by an electric motor capable of applying a defined amount of speed and torque. This applied input torque is then amplified by the worm gear ratio while the speed is reduced proportionally. The amplified torque at the gear output shaft is then applied to the external load to perform the desired work.

It is important to note that there are some applications where the load characteristics cause a reversal of this normal flow of power from the input to the output of the speed reducer. This would apply where the reducer is being used as a worm gear speed increaser. Examples also include a worm gear speed reducer used on an overhead crane or vertical lift. Unless perfectly counter balanced a crane normally consumes input power during lifting operations, however when it is desired to lower the load, the load will apply a reverse torque to the output gear shaft as the load attempts to rapidly descend under the force of gravity. To prevent an undesired rapid decent of a vertical crane load it is required that the worm gear speed reducer absorbs power and provide a braking or reverse torque to the load. This kind of application is often referred to as an overhauling load.

Another overhauling application would be where a high inertia load is required to rapidly decelerate faster than friction forces alone would cause to occur. In this situation, as with many crane loads, it is desired that the speed reducer output smoothly apply a braking or reverse torque to the load in order to achieve desired operation.

Self-Locking:

Certain worm gear speed reducers have worm and gear geometries that prohibit dynamic reverse torque operation. Any torque reversal on the output shaft will cause the worm gear mesh to instantly lock up and the reducer will refuse to rotate. Great damage to perhaps both the worm gear speed reducer and the load may be the result when a gear mesh instantly locks up. Inherent characteristics in certain worm gear designs allow the reducer to immediately lock up the worm and gear mesh in reverse torque applications.

The causes of "lock up" behavior are complex. All worm gear designs exhibit components of both sliding and rolling friction in the worm thread and gear tooth mesh. When the friction component in the gear mesh reaches a critical amount, self locking can be the result. Many factors determine when this critical amount of mesh friction occurs, these include: the worm lead angle; the rotational speed; the reduction ratio; the type of gear tooth geometry used; gear and worm surface finish and hardness; temperature; the type and condition of the lubricant; the magnitude and frequency of any external vibration forces; any load pulsations; and the magnitude of the overhauling load.

Often, in a specific application, the point at which a particular self locking worm gear speed reducer actually locks up when static will be different than when it locks up dynamically. Specifically, selected self locking worm gear speed reducers may not dynamically self lock, but rather will freely back drive dynamically. However, this same reducer, once all rotation ceases, and it is stationary for some time, the reducer will self lock; even when a great deal of torque is applied to the output shaft. The result is that smooth acceptable operation with an overhauling load occurs when the reducer is running but once the reducer is stopped, it will not permit any rotation. In these situations the worm gear speed reducer is operating similar to the function provided by a static load brake.

Winsmith does not recommend or approve of the use of any worm gear speed reducer in any application where operational self-locking characteristics are used to replace a static or dynamic brake. Neither dynamic nor static self-locking performance of a worm gear speed reducer should ever be relied upon whenever any unintended load rotation might possibly result in damage or harm to either machinery or people. Self-locking Winsmith worm gear speed reducers should never be used to provide the function of a "fail safe" brake.

Speed Reducer Self-Locking and Back-Driving

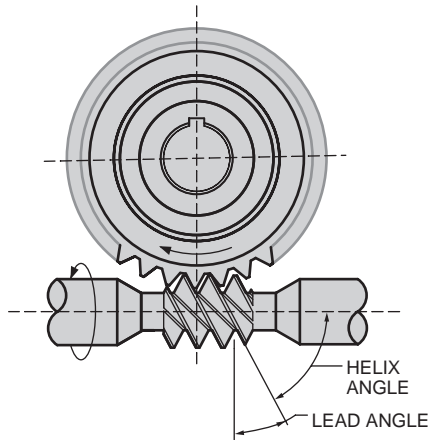

Figure 1.

When is a worm gear reducer considered to be Self-Locking?

Statically self-locking worm gear speed reducers can be obtained when the lead angle (Figure 1 above) of the worm threads is less than the sliding static friction angle (Figure 2 above) of the worm and gear. The sliding static friction angle of any two components is the angle at which, in Figure 2 above, the stationary block just starts to slide down the ramp shown. This angle is a primary function of the materials used to make the components and any lubricant applied at the sliding surfaces. For a bronze gear and a hardened steel worm operated in a typical worm gear speed reducer, the sliding static friction angle is generally assumed to be less than around eight (8) degrees. The sliding static friction angle may be lower than eight (8) degrees due to factors such as; surface finish, type of lubricant, condition of lubrication at the surfaces, and the presence of external vibration or load pulsations. After a reducer has run-in, the gear teeth become polished and thus the coefficient of friction angle is reduced. When static self locking is desired in an application, consideration must be given to the many factors including even the normal manufacturing tolerances that create variations in the lead angle of any specific worm or gear component part number.

The sliding dynamic friction angle is the angle, in Figure 2, where even when the block is in motion it will almost cease moving down the ramp. Under dynamic or rotating conditions of a worm and gear set, the sliding dynamic friction angle of the worm and gear is dependent on all the above discussed factors plus additionally it is a function of the rotational speed and the dynamic lubrication performance. For a bronze gear and a hardened steel worm operated in a typical worm gear speed reducer, the sliding dynamic friction angle is generally assumed to be less than around

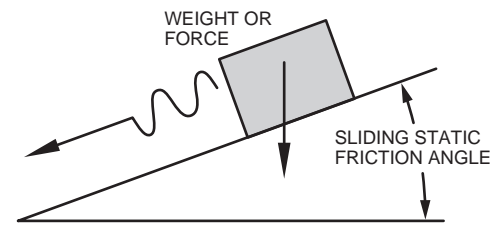

Figure 2.

2 degrees. If a worm gear reducer is selected with a worm thread lead angle of less than about 2 degrees it will normally dynamically self-lock. This means that whenever an external output load begins to overhaul or back drive the gear reducer, an abrupt immediate gear mesh lock-up or an intermittent or momentary lock-up is likely to occur. This almost always will result in serious, and perhaps permanent, damage to the worm gear speed reducer and perhaps also damage the driven load or machinery.

When a worm gear speed reducer is selected with a worm lead angle between a static sliding friction angle of about 8 degrees and a sliding dynamic friction angle of about 2 degrees, the reducer may exhibit both static self-locking, and at the same time, dynamic back-driving characteristics. The above operational characteristic of selected worm gear speed reducers may be extremely desirable in many applications where dynamic braking and static locking are desired. However, great care and prototype testing may be necessary in order to insure that the desired performance is achieved in a specific application. When the lead angle on worm threads is below 8 degrees, intermittent or momentary dynamic self-locking may also occur. When this occurs it is sometimes referred as "stick-slip" or "stair-stepping" operation and is generally undesirable and destructive.

NOTE:

The lead angles of the SE Encore Series were designed intentionally high for improved worm gear mesh power transfer efficiency. Depending on center distance, some sizes will have a tendency to be statically self-locking at 30:1 ratio and other sizes may not statically self lock at ratios as high as even 50:1. However, many special worm and gear ratio geometries are available to address various operational performance desires. Lead angles are not published, check with Winsmith for applications assistance.

